

WESTERBEKE 40

marine diesel engine

formerly FOUR-107

The **WESTERBEKE 40**, for many years America's most popular marine diesel, is our original model, the one most people affectionately refer to as "a Westerbeke." Over 15 years of development have gone into making this engine the most compact, most versatile, and most dependable marine diesel available.

The profile has been constantly reduced for compactness and for accessibility. A long list of options plus a long list of standard equipment virtually gives you a custom built engine. With our plug-in engine pre-wiring and adjustable engine mounts, the **WESTERBEKE 40** is the easiest engine to install — a boatbuilder's dream.

For years Westerbeke owners have mentioned the engine's reliability under extreme conditions. It has been approved by the U.S. Coast Guard for use on lifeboats. It powers generator sets on remote aids to navigation. It is used where lives depend on its instant starting and dependable running capability.

If you're bound offshore, or off the beaten track, you need the dependability of the **WESTERBEKE 40**.

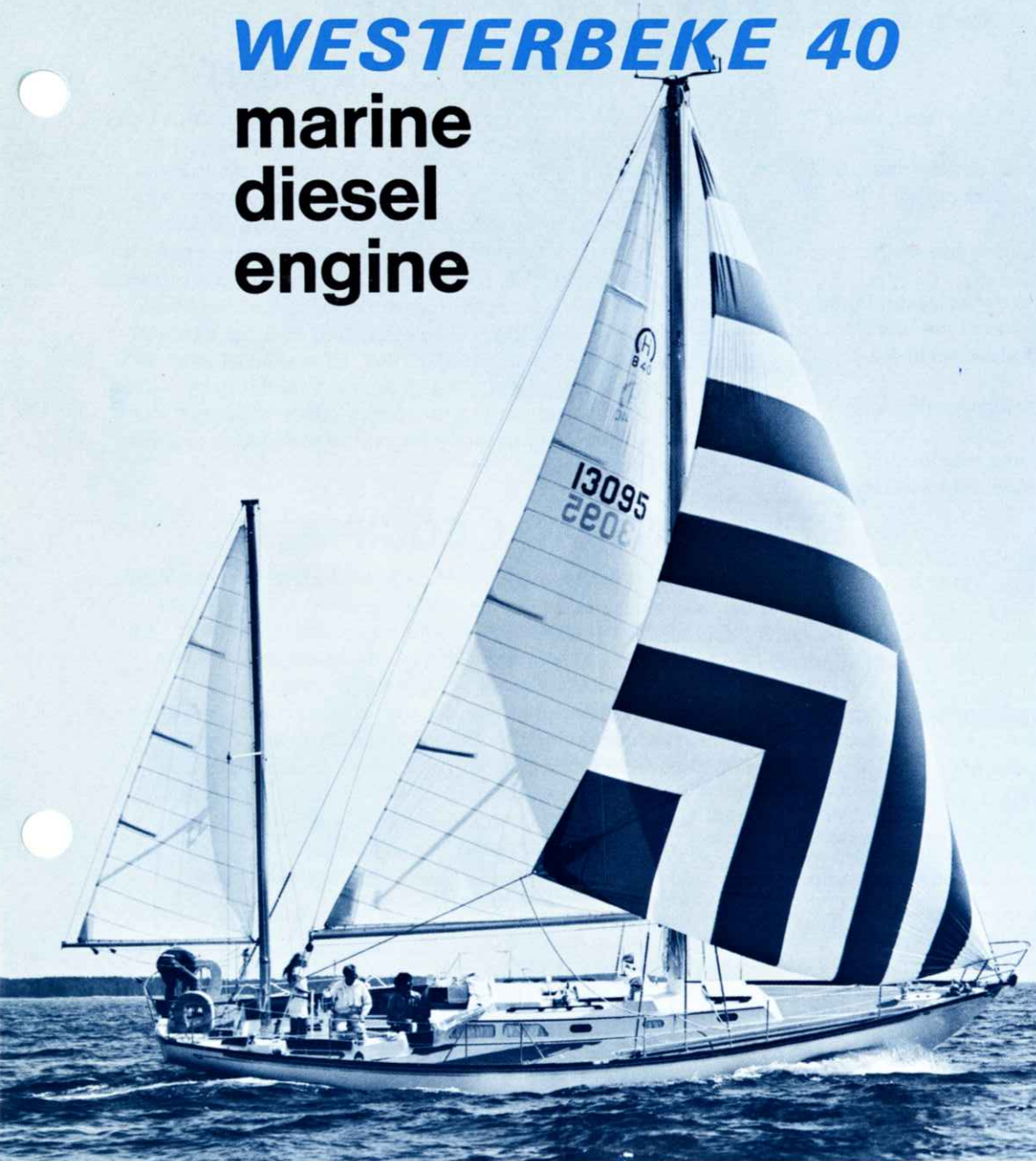

BERMUDA 40 by Hinckley

WESTERBEKE 40 with Paragon 2:1 SAO manual gear

WESTERBEKE 40 with Paragon P23 3:1 hydraulic gear

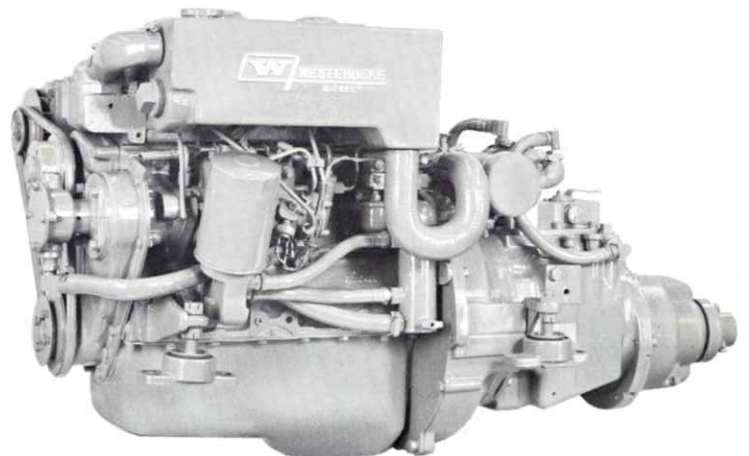
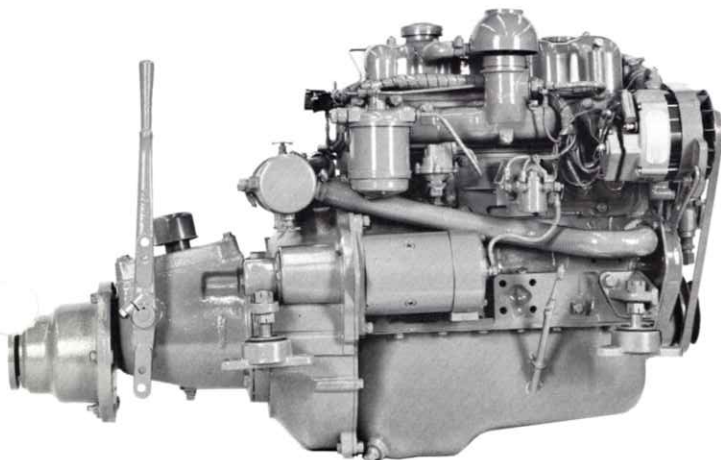

WESTERBEKE 40

SPECIFICATIONS

Type: Four cylinders in line, four cycle fresh water cooled diesel.

Displacement: 107 cu. in. Bore 3.125", Stroke 3.5".

Power: 37 hp at 3000 rpm (see power curve).

Compression Ratio: 22:1.

Weight: 474 lbs. basic engine. Add gear weight opposite page for I.O.R. weight.

Fuel Injection Equipment: Distributor type fuel pump with mechanical governor and pintle type injectors.

Cylinder Block: One-piece iron alloy casting with replaceable liners.

Cylinder Head: One-piece iron alloy casting with renewable valve guides.

Crankshaft: Chrome molybdenum steel forging.

Main bearings: Three, replaceable, thin wall, lead bronze lined.

Camshaft: High duty cast iron.

Pistons: High silicon aluminum alloy.

Connecting Rods: Drop forged steel.

Lubrication: Eccentric lube oil pump, camshaft driven. Full flow spin-on lube oil filter.

Mounting: Flexible mounts, adjustable to 16" or 18" centers. Special mounts available on request.

Exhaust Manifold: Fresh water cooled, front or rear exhaust.

Cooling System: Closed circuit fresh water system. Fresh and raw water pumps, engine-mounted.

Angle of Installation: 17° maximum.

Electrical System: 12 volt negative ground system with 55 amp alternator standard. Extra 55, 85 or 120 amp alternators available.

Transmission: See individual gears on opposite page for specifications and propeller rotation.

Installation Data: 1½" IPS exhaust flange; ½" IPS raw water inlet; fuel inlet ¼" tubing, fuel return ⅜" tubing.

STANDARD EQUIPMENT

Fresh water cooling system with heat exchanger, surge tank, and pumps, mounted on engine; flexible mounts adjustable to 16" or 18" centers; propeller shaft coupling; clutch lever with lower extension for remote control where applicable; spin-on full flow lube oil filter, lube oil cooler, sump pump and hose; engine-mounted secondary fuel oil filter, fuel lift pump with hand primer, flexible hoses for fuel inlet and return, mechanically governed fuel injection system; cold weather starting aid, mounted and piped; 12 volt, 55 amp alternator with transistor regulator; plug-in engine pre-wiring including pre-wired start panel with 10 foot cable; threaded 1½" IPS exhaust flange; fully illustrated Instruction Manual and Parts List.

OPTIONAL EQUIPMENT:

High efficiency primary fuel filter; Hydro-Hush stainless steel water lift muffler, water injected exhaust elbow, flexible stainless steel exhaust section; sea water strainer, remote fresh water expansion tank; remote lube oil filter, front-end lube oil fill; pre-wired all-electric instrument panel, with 10-foot cable, pre-wired mechanical instrument panel with tachometer cable, extra 10 foot cable for instrument panels or starting panel; high temperature, low pressure alarm system; extra 55, 85, 120 amp alternators, engine-mounted; crankshaft-mounted accessory pulleys, 5", 6" or 7" diameter; flexible shaft coupling; special engine mounts; spare parts kits.

PEARSON 365 by Bill Shaw

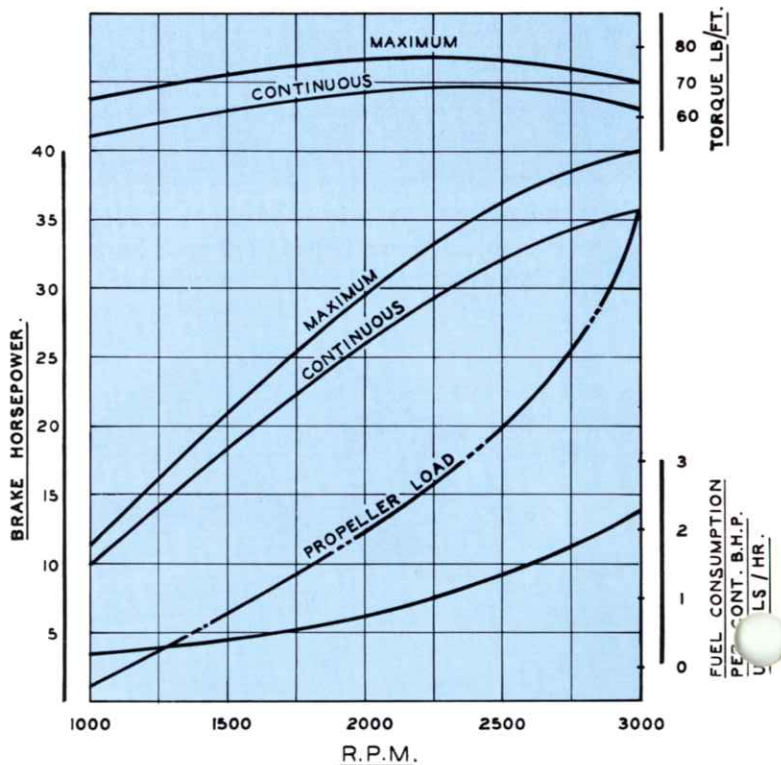

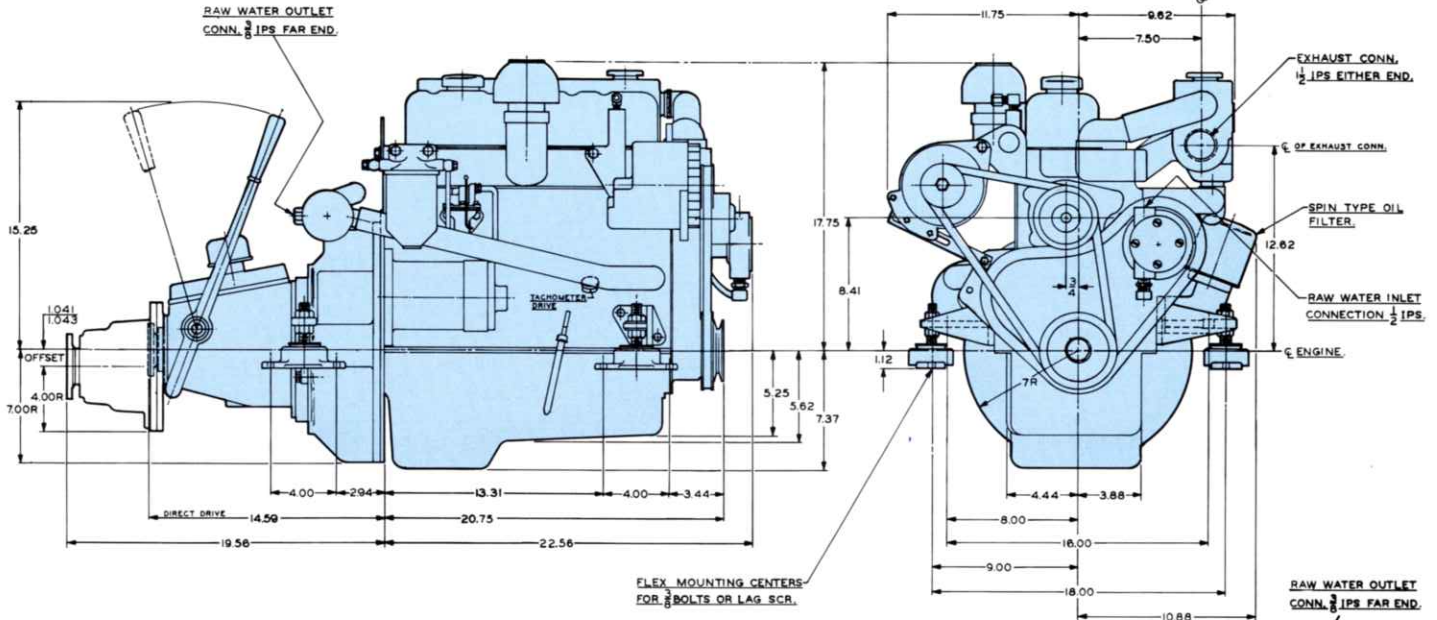

The drawing above shows our standard WESTERBEKE 40 model SAO Paragon direct drive manual gear. This extremely reliable gear weighs only 58 lb. It turns left hand propeller. **PARAGON SAO with reduction gear** Two reduction ratios — 1½, and 2 to 1. Weight 82 lb. See table for dimensions. Turns left hand propeller.

WESTERBEKE Short Profile Sailing Gear
The most compact 2:1 reduction package ever! It features positive neutral for free-wheeling, silent-running, shaved, case-hardened helical gears, heavy-duty tapered roller bearings, and an instant acting fingertip control lever. (Use Morse 33C cable or equal.) Weight 25 lb. Turns right hand propeller.

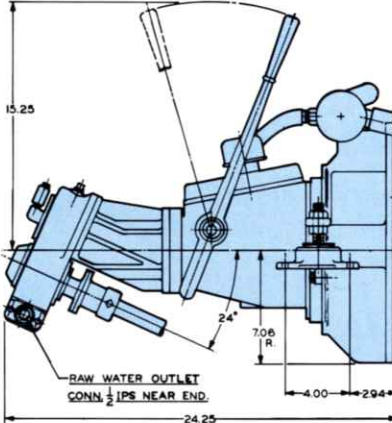

RATIO	DIM. A	DIM. B	OFFSET
1.50:1	21.62	4.50	0.85
2.04:1	21.62	4.50	1.30
2.52:1	21.93	5.25	1.90
3.00:1	21.93	5.25	2.10

PARAGON SAOV
This manual vee drive is very useful with our front end exhaust outlet in many designs. It is available in ratios of 1.29:1, 1.67:1, 2:1, and weighs 90 lbs. Turns left hand propeller.

WESTERBEKE-PARAGON P220 Hydraulic Navy Gear
Specially developed to Bureau of Ships specifications. It is oversized and built for use on diesel engines up to 75 horsepower. It may be used with a WESTERBEKE 40 on large sailing craft that can make use of a 4" offset, 2.2:1 reduction ratio, and right hand propeller. Weight 166 lb.

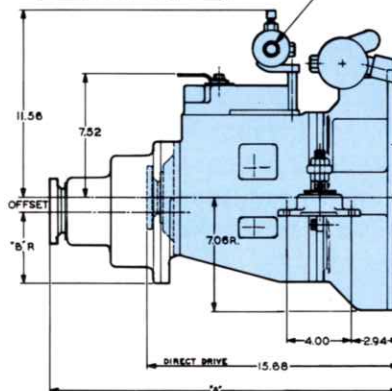
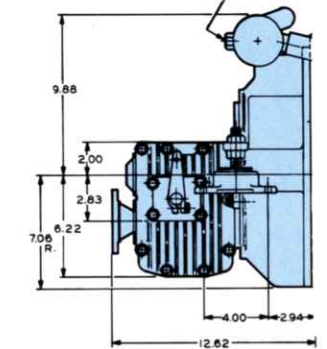

PARAGON P20 Hydraulic Gear
Available with direct drive and in 1½, 2, 2½, and 3 to 1 ratios. A quality unit employing latest design principles. The small offset (see table) can be turned down or up to suit the installation. Weight, direct drive 100 pounds, reduction gear 150 pounds. Turns left hand propeller.

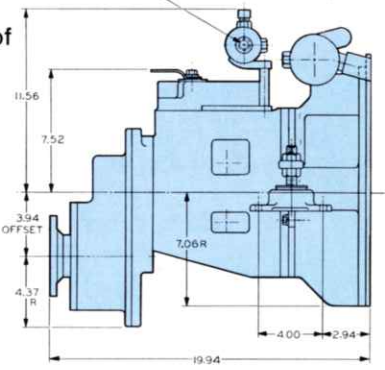

WARNER Hydraulic Gear
This excellent transmission is of in-line construction with no offset. Available with direct drive and 1½, 2, 2½, 3 to 1 ratios for left hand propellers and 1.9:1 for right hand propellers. Weight — direct drive 96 pounds, reduction gear 147 pounds.

PARAGON Hydraulic Vee Drive
A Paragon P20 hydraulic gear close-coupled to a Walter vee-drive. Ratios of 1.29:1, 1.67:1; and 2:1. Weight 132 lb. Turns left hand propeller.

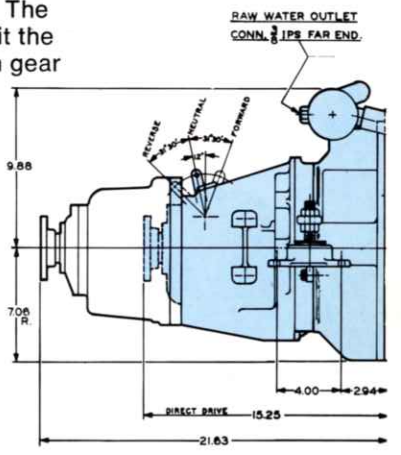
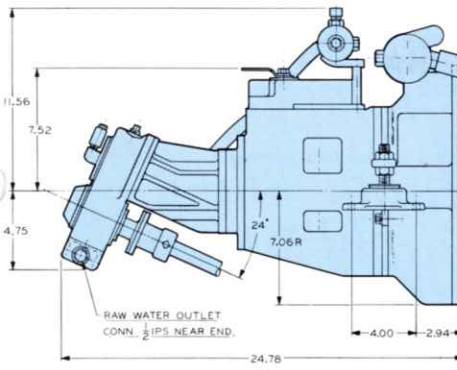

**WESTERBEKE 40 with Westerbeke Short Profile Sailing Gear
35" overall length — the most compact
2:1 package ever**

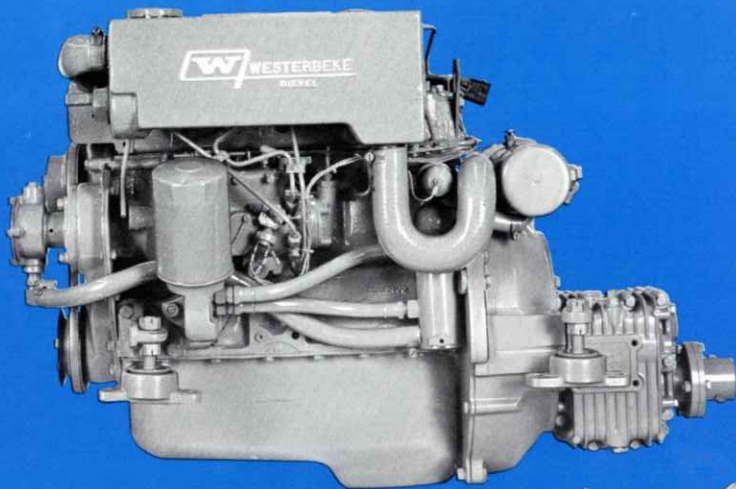

**WESTERBEKE 40 with Paragon SAOV
manual vee drive**

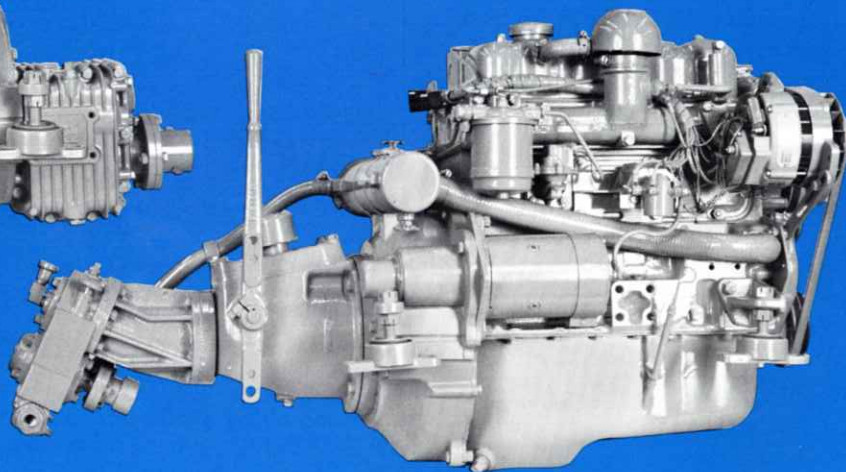

WESTERBEKE 40 — for many years America's most popular diesel engine for sailboats

WESTERBEKE 40, the Custom Engine

A long list of options added to an unusually large number of standard items lets you customize your WESTERBEKE 40 to your boat. Numerous transmission options include manual or hydraulic, reductions from 1:1 to 3:1, shaft offsets from 0" to 4", straight or vee drive. Adjustable flexible mounts are standard on 16" or 18" centers. Many other mounts are available on application.

Remote surge tank, lube oil filter and front-end lube oil fill are available for tight installations. Accessory pulleys and extra alternators are available to run added equipment. Plug-in prewiring saves much installation time and money. Complete prewired instrumentation gives accurate engine performance data and

permits the installation of engine safety alarms. A high efficiency exhaust system gives unusually quiet performance.

These custom features plus many others let you order the engine you want to suit your boat, whether it's a rough and ready seine skiff or the ultimate cruising yacht with all accessories. The versatile WESTERBEKE 40 has been used in all types of boats from catboats to Class A ocean racers.

The adaptability, compactness and proven performance records of the WESTERBEKE 40 are unsurpassed. The many thousands of satisfied Westerbeke owners bear testimony to this, as does their high rate of reordering for their new boats. Ask a Westerbeke owner near you.

Westerbeke engines and generator sets are sold and serviced by Westerbeke distributors in major port cities throughout North America.



J. H. WESTERBEKE CORP.

AVON INDUSTRIAL PARK, AVON, MASS. 02322 • (617) 588-7700

CABLE: WESTCORP, AVON • TELEX: 92-4444